

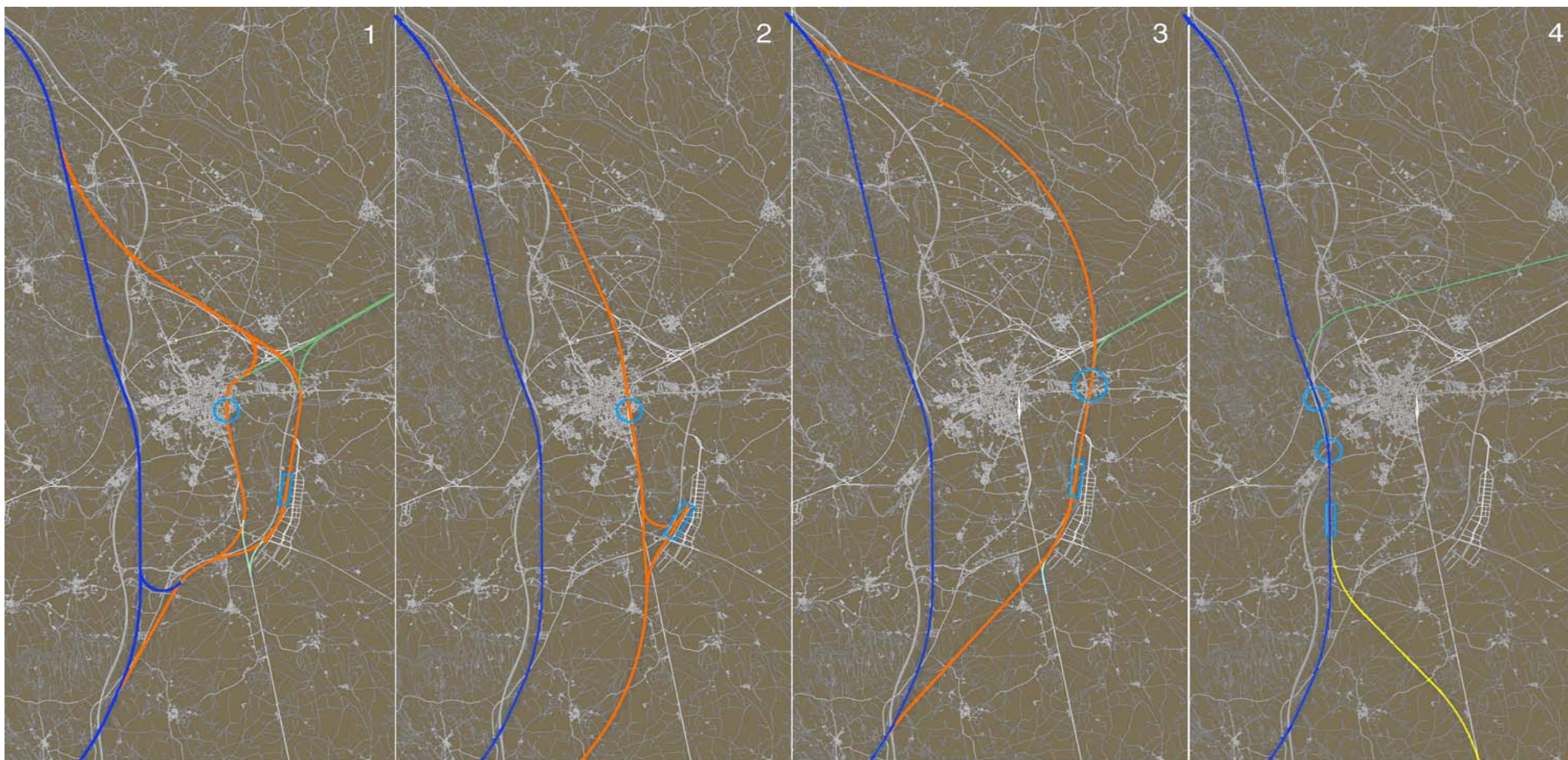

INTERREG III

31 març 2006. Ville de PERPIGNAN
El proyecto urbano para Figueres
Ayunt. de Figueres - UPC

La estrategia urbana y territorial de Figueres Siglo XXI



 Trazado de LAV, propuesto por el ministerio

 Trazados alternativos de la LAV a su paso por Figueres

 Línea de ancho ibérico

 Línea de ancho europeo

 Estación de pasajeros

 Estación de mercancías

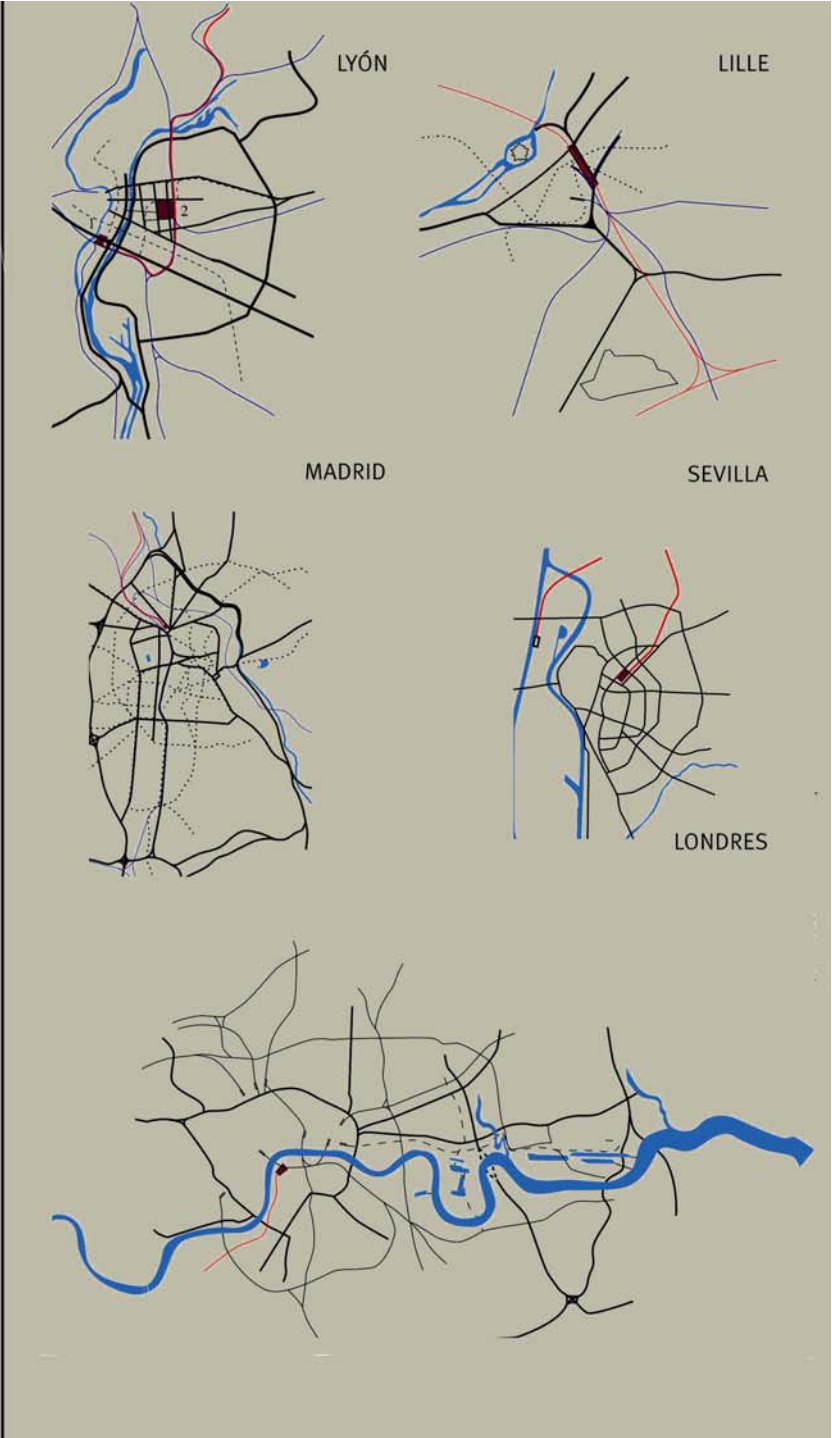
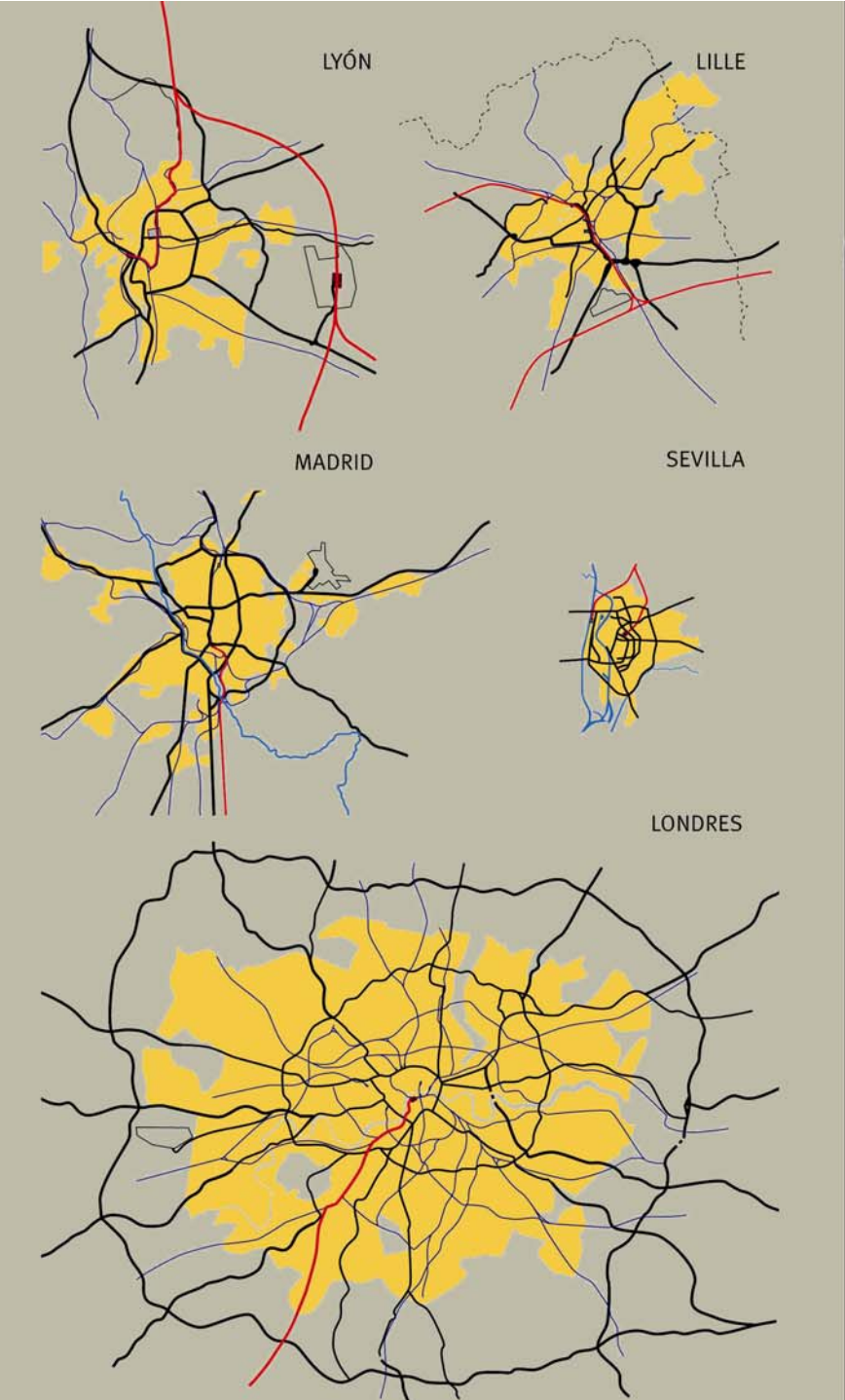

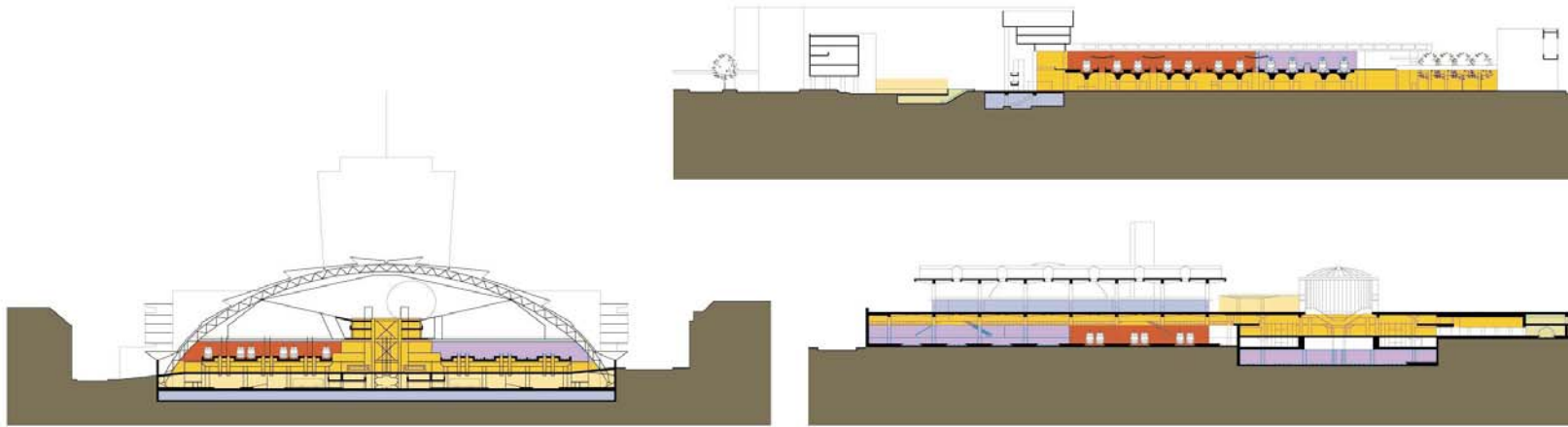

Secciones

- La estación de La Part- Dieu, de Lyon. ↗
- Intercambiador de Abando, en Bilbao. ↗
- La estación de atocha, en Madrid ↗
- Intercambiador de Parrache, en Lyon. →

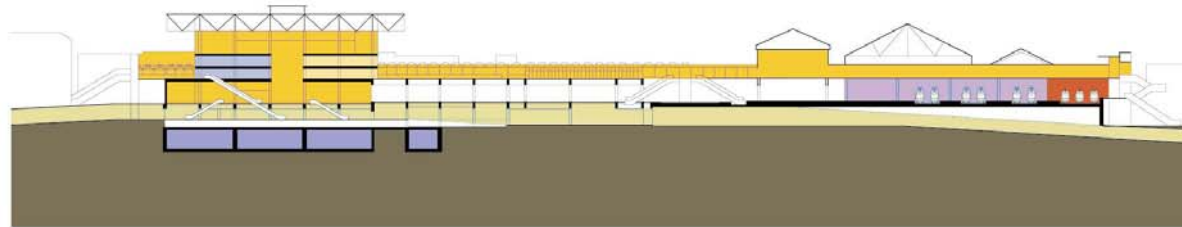

Secciones

Sección de las estaciones de:

- Euralille, Lille →
- Santa Justa, Sevilla ↓
- Roissy, París ↘
- Satolas, Lyon ↘
- Waterloo (terminal), Londres ↘

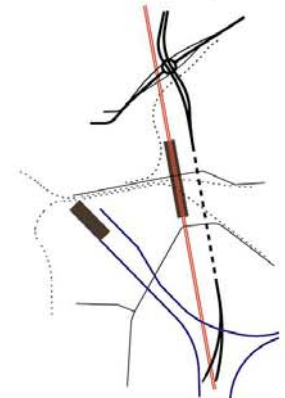
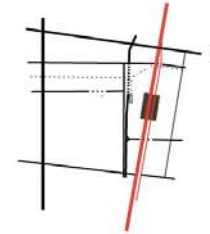
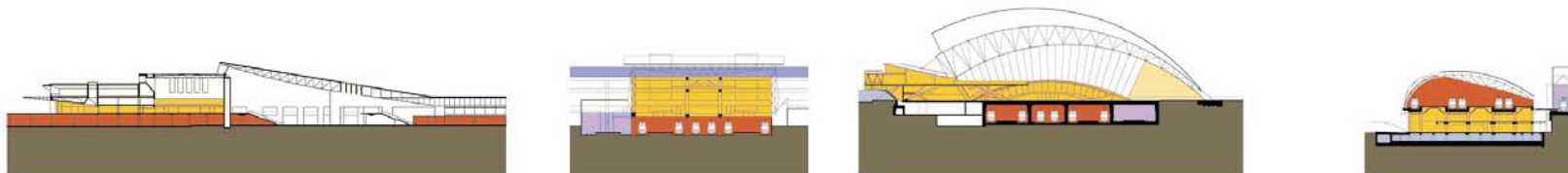
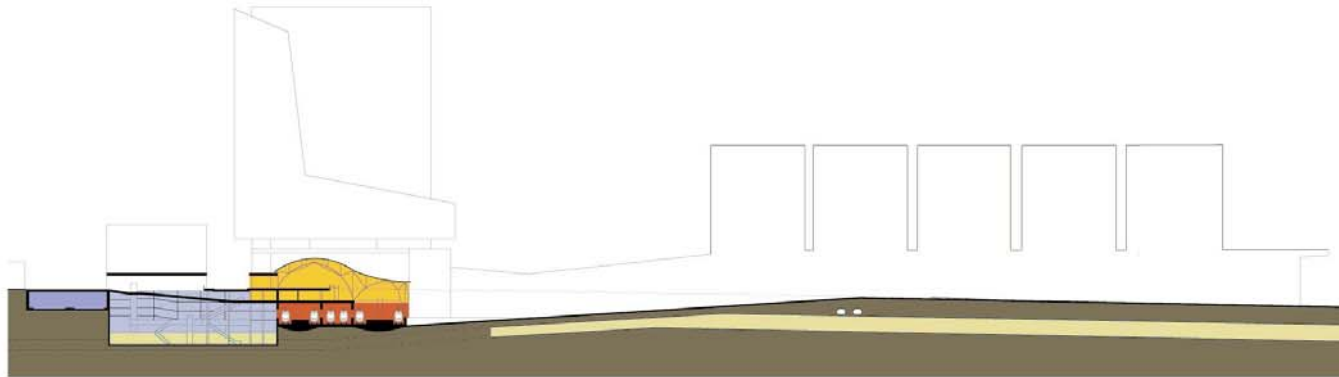

	UDG	UPC	UB
Estudios de carácter general	Demografía		Actividades Económicas
Estudios de carácter específico	Area urbana <i>versus</i> dinámica urbana		
		La construcción del territorio desde las infraestructures	
	Paisaje natural <i>versus</i> paisaje construido		
Proyecto		INTERREG II	
		PLAN ESPECIAL "Avinguda Nova Estació"	

Area urbana versus dinámica urbana

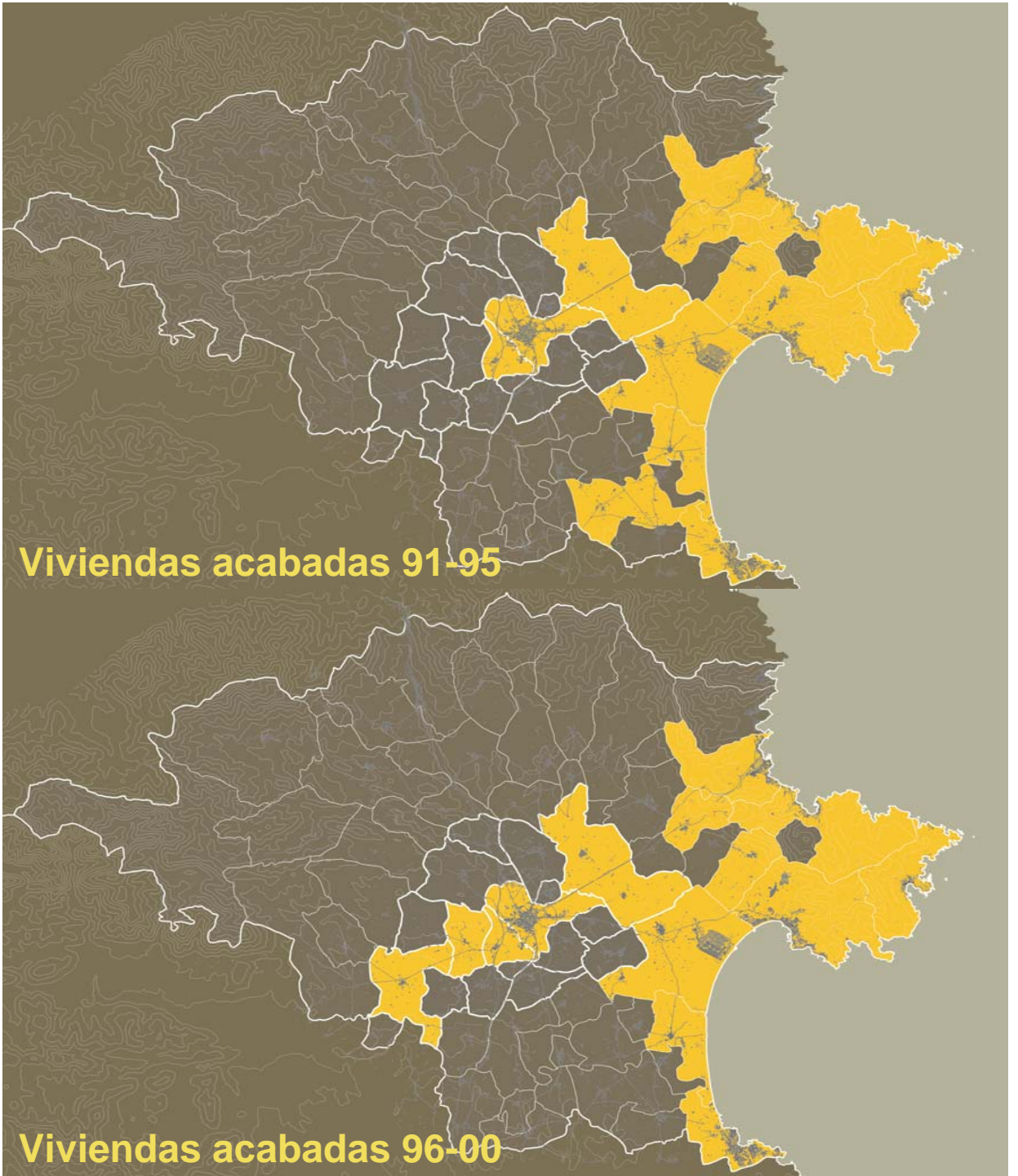
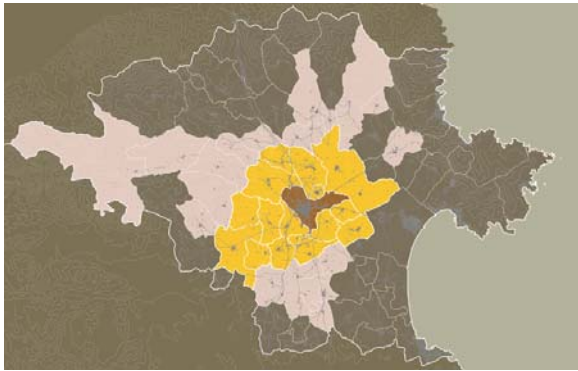

Viviendas acabadas 91-95

Viviendas acabadas 96-00

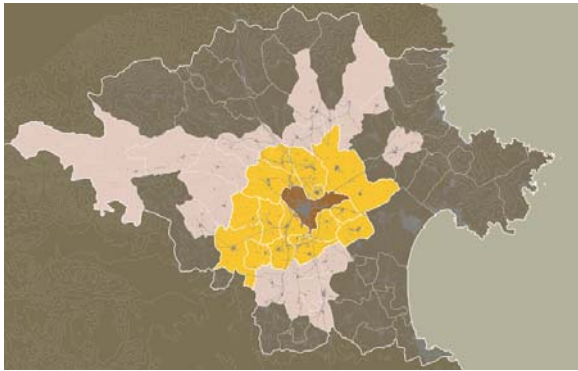

**Planes Parciales
residenciales aprobados**

**Planes Parciales
industriales aprobados**

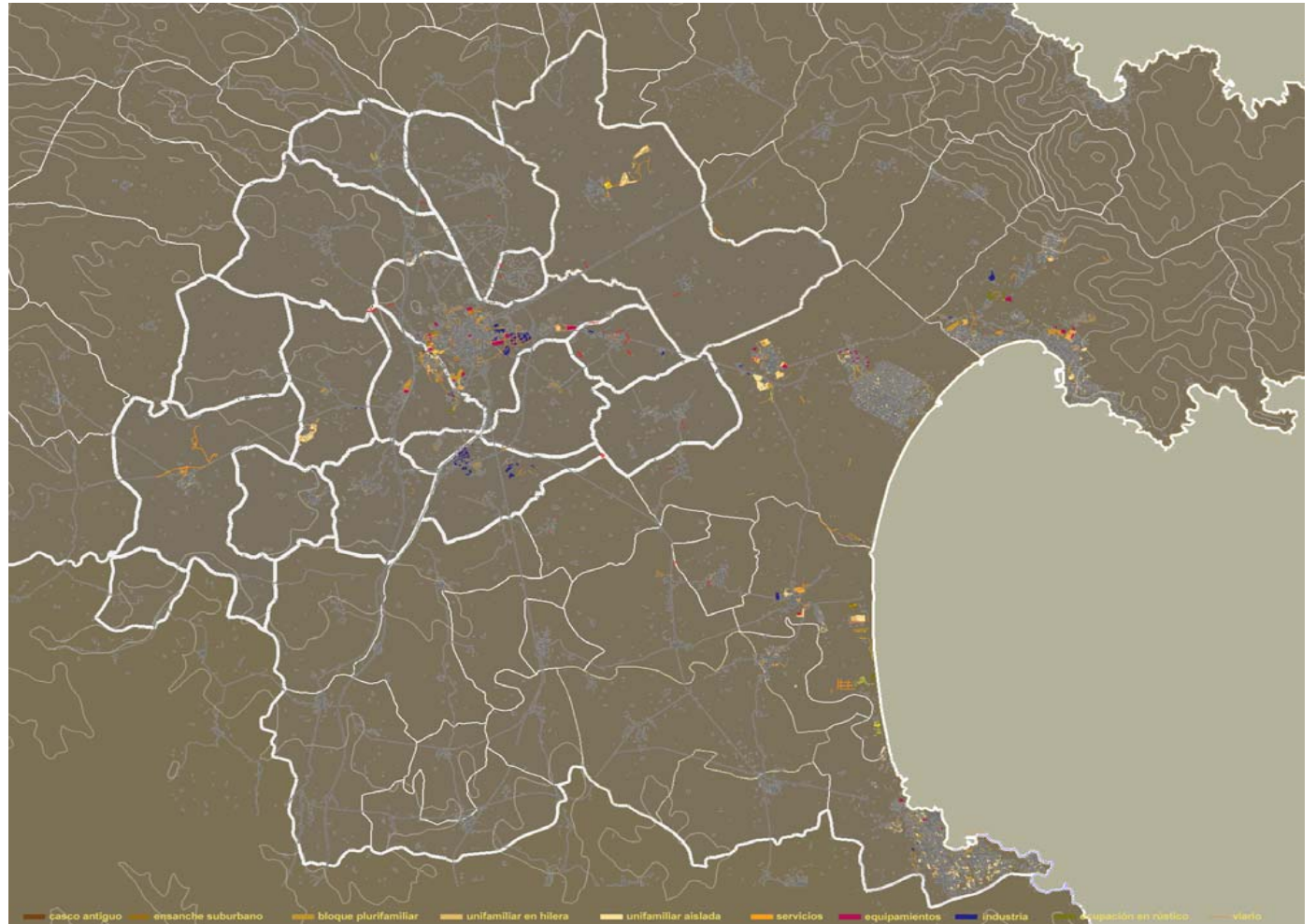
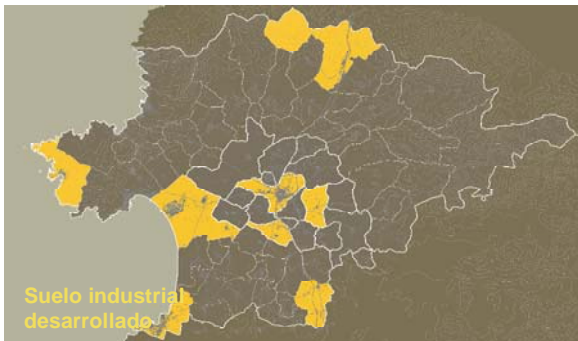
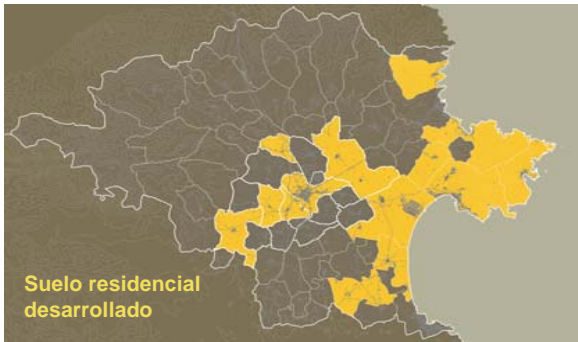
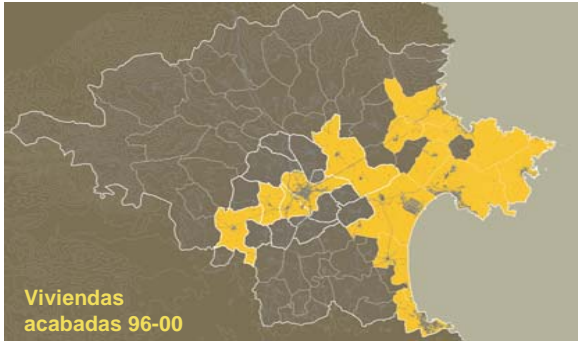
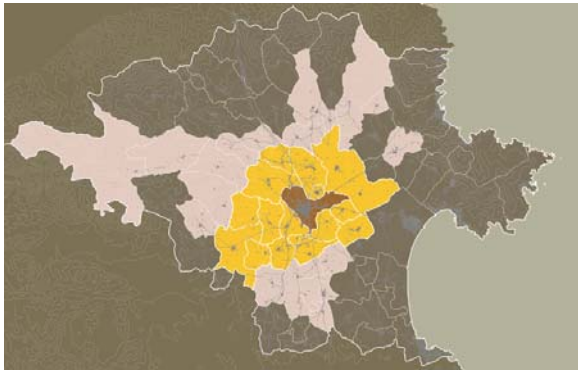

Crecimientos 96-00

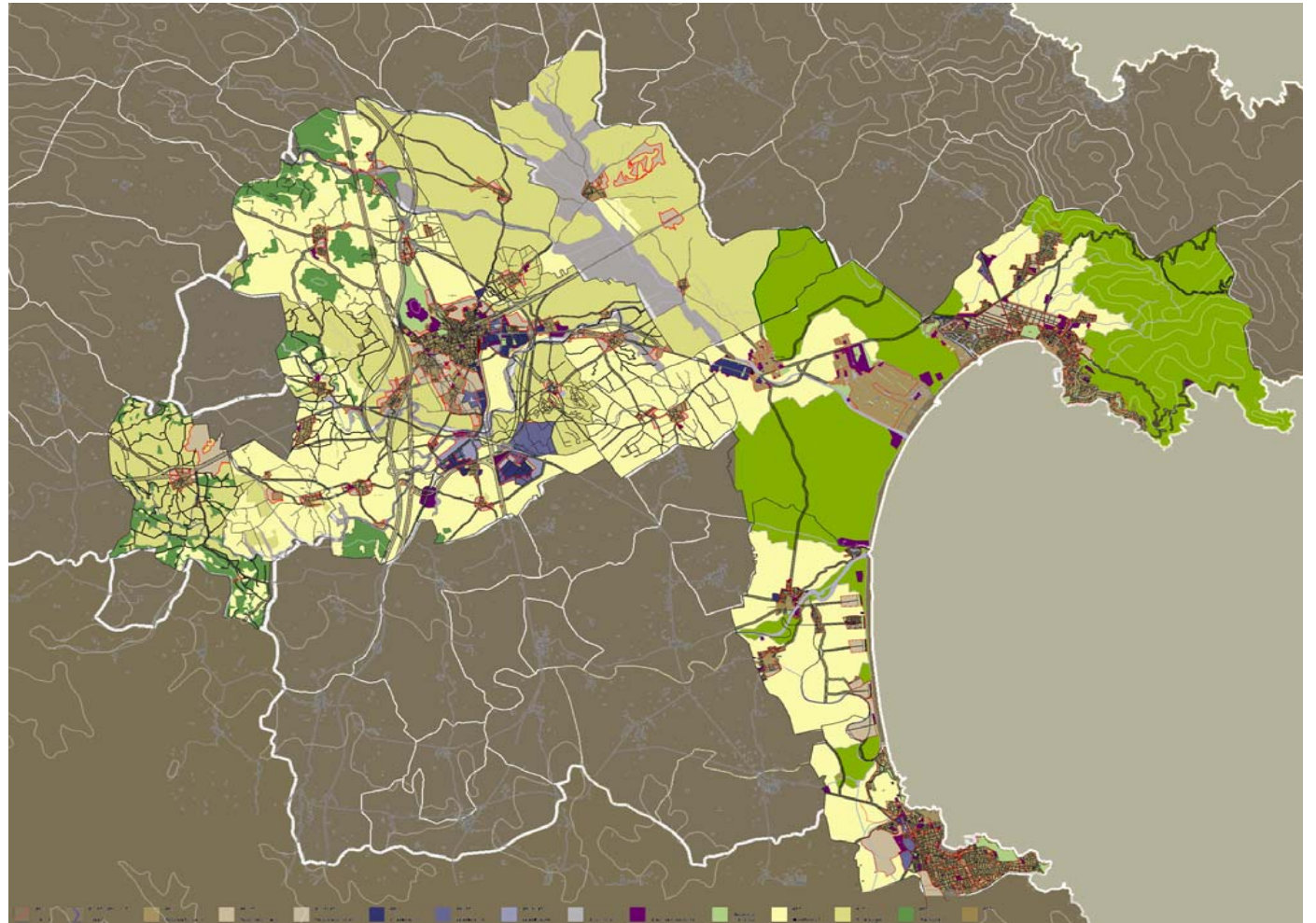
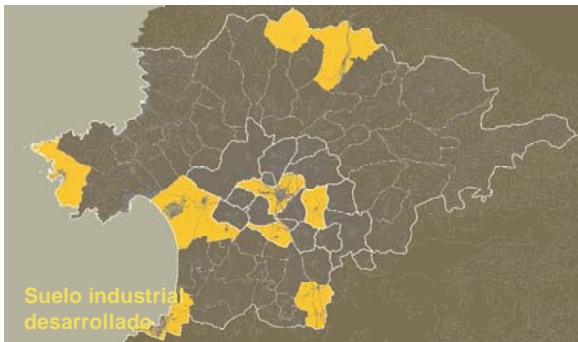
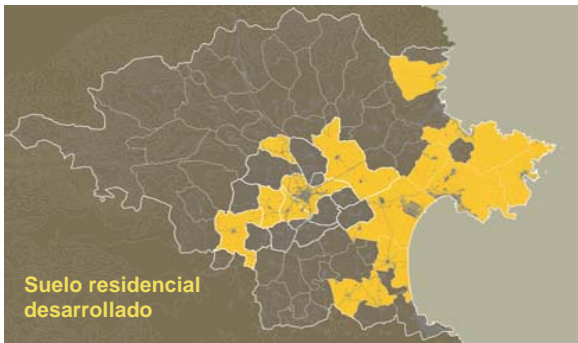
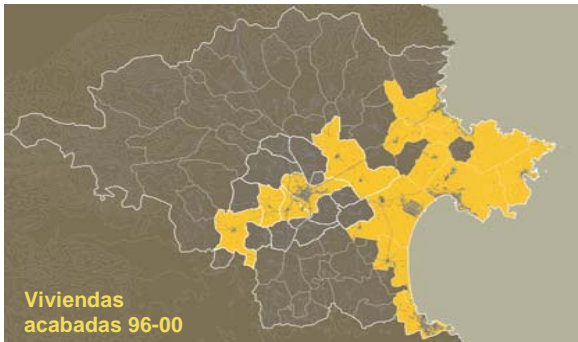
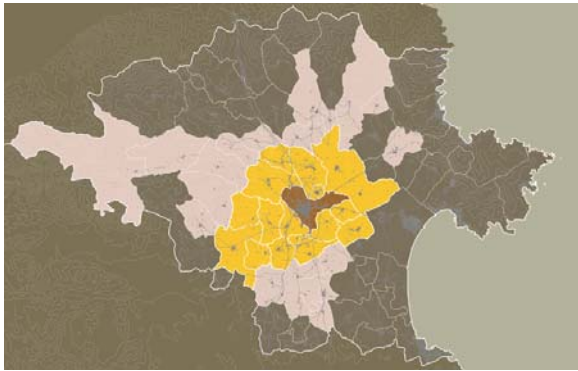

Planeamiento 03

La construcción del territorio desde las infraestructuras

Alt Empordà

sistema topográfico



sistema hidráulico



sistema de caminos



sistema de ocupación del suelo



sistema de infraestructuras global



sistema de infraestructuras local



sistema de infraestructuras global y local

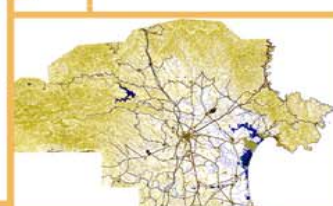

Figueres

sistema topográfico

sistema hidráulico

sistema de caminos

sistema de ocupación del suelo

sistema de infraestructuras global

sistema de infraestructuras local

sistema de infraestructuras global y local

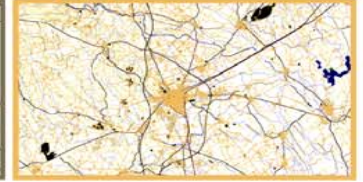
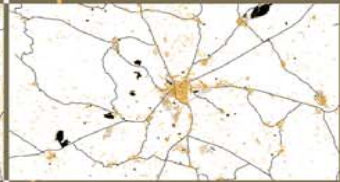
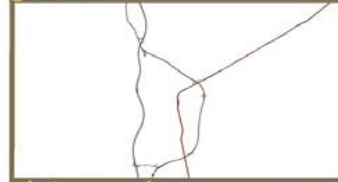

Paisaje natural versus paisaje construido

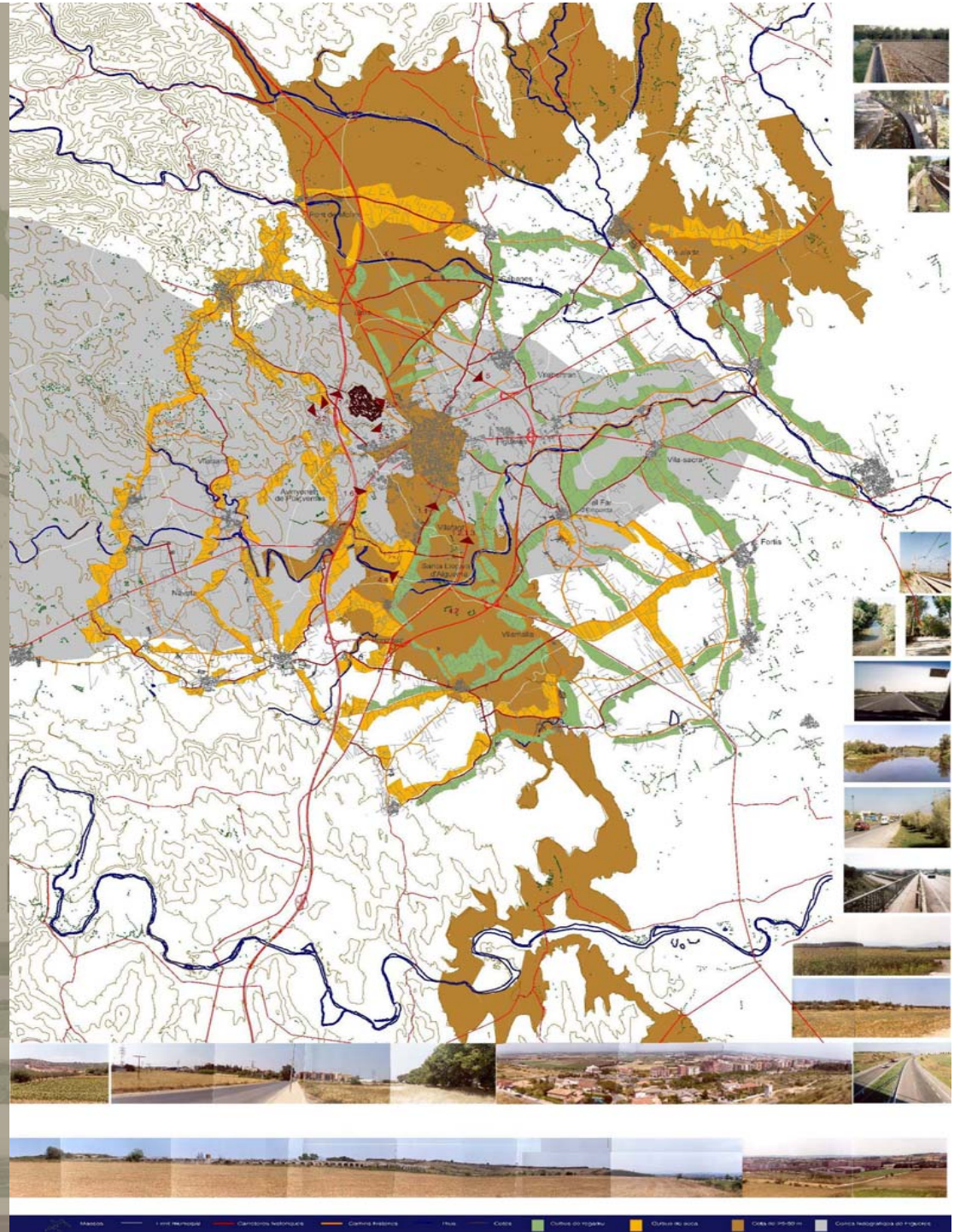
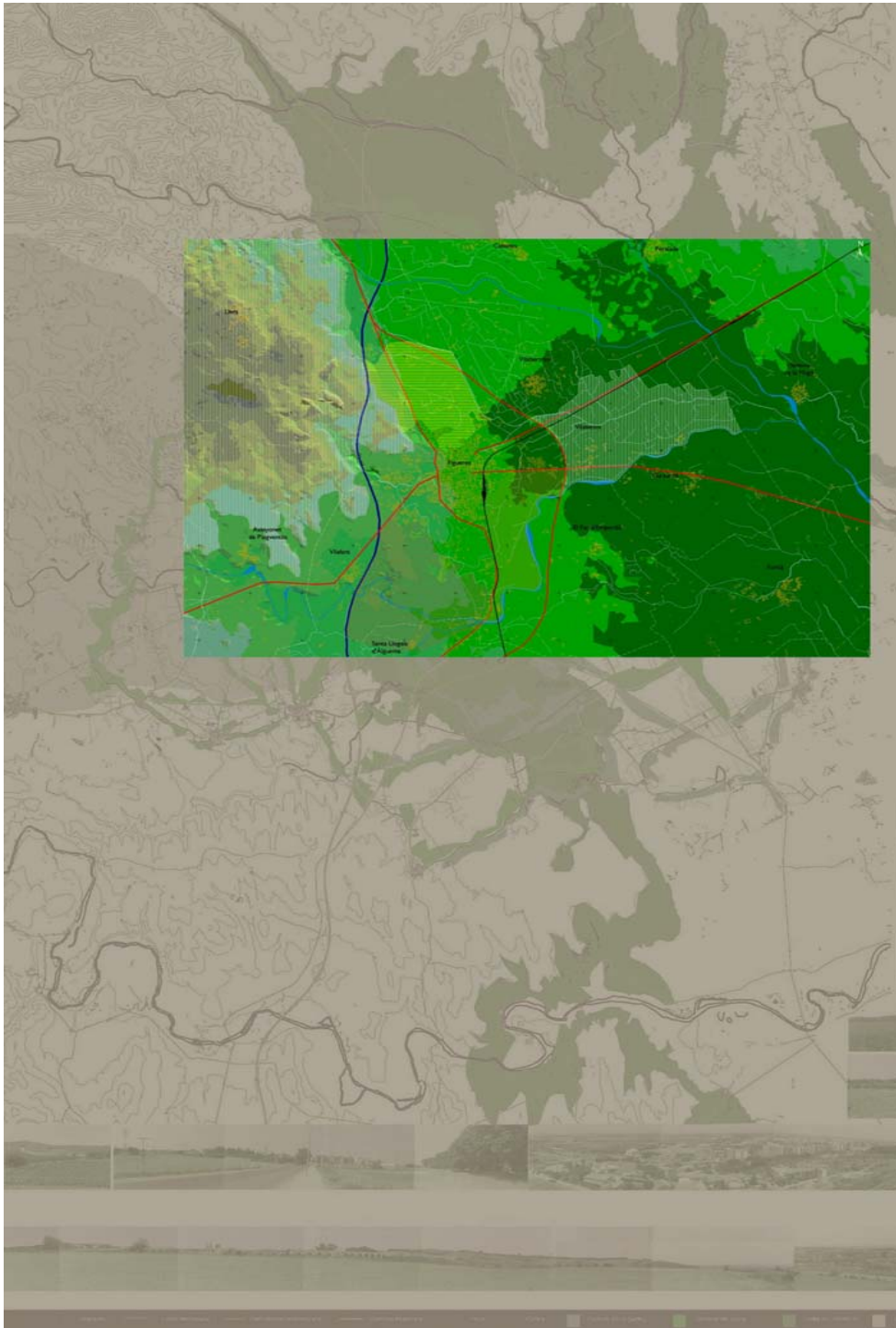

Proyecto INTERREG III

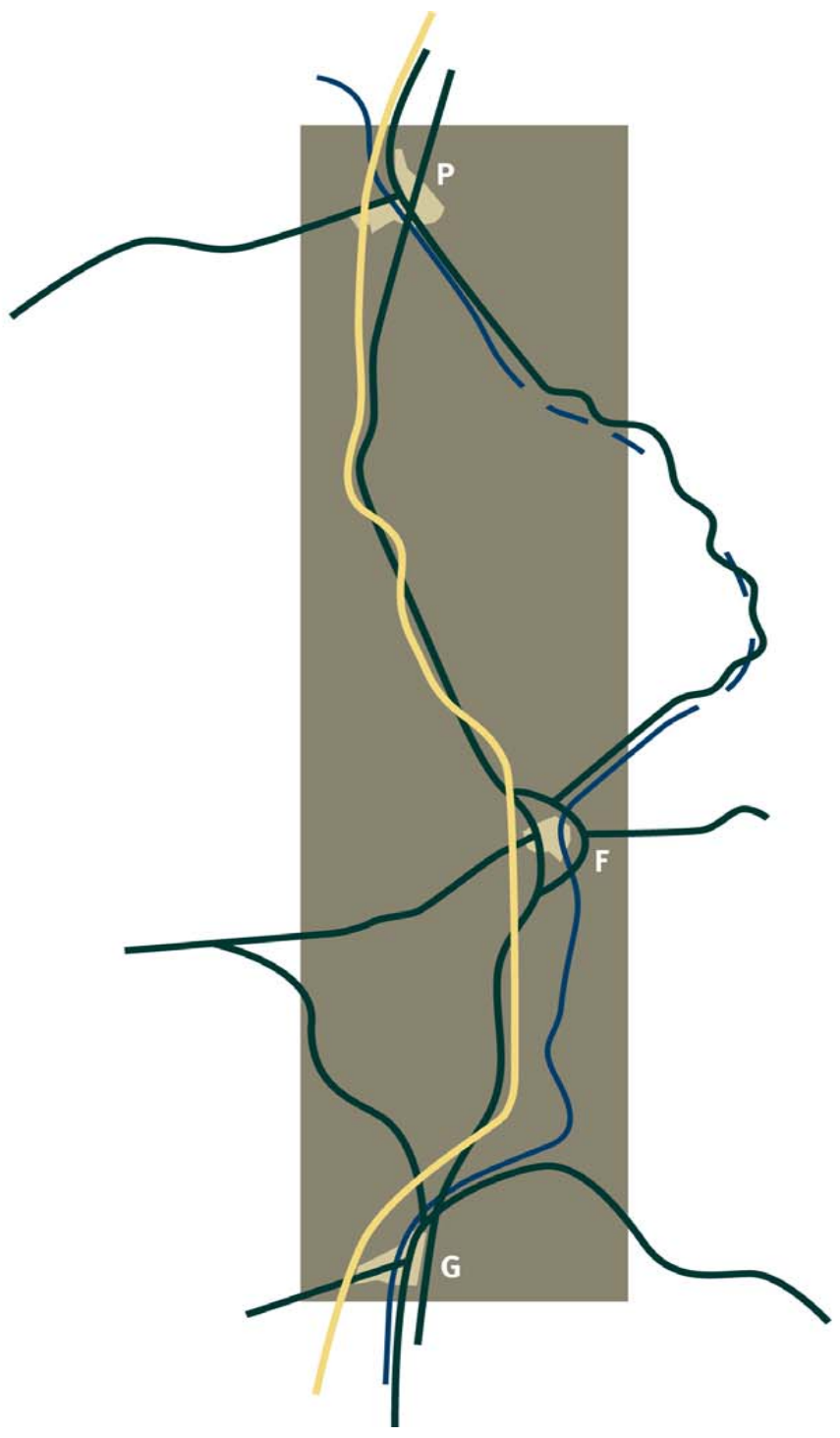

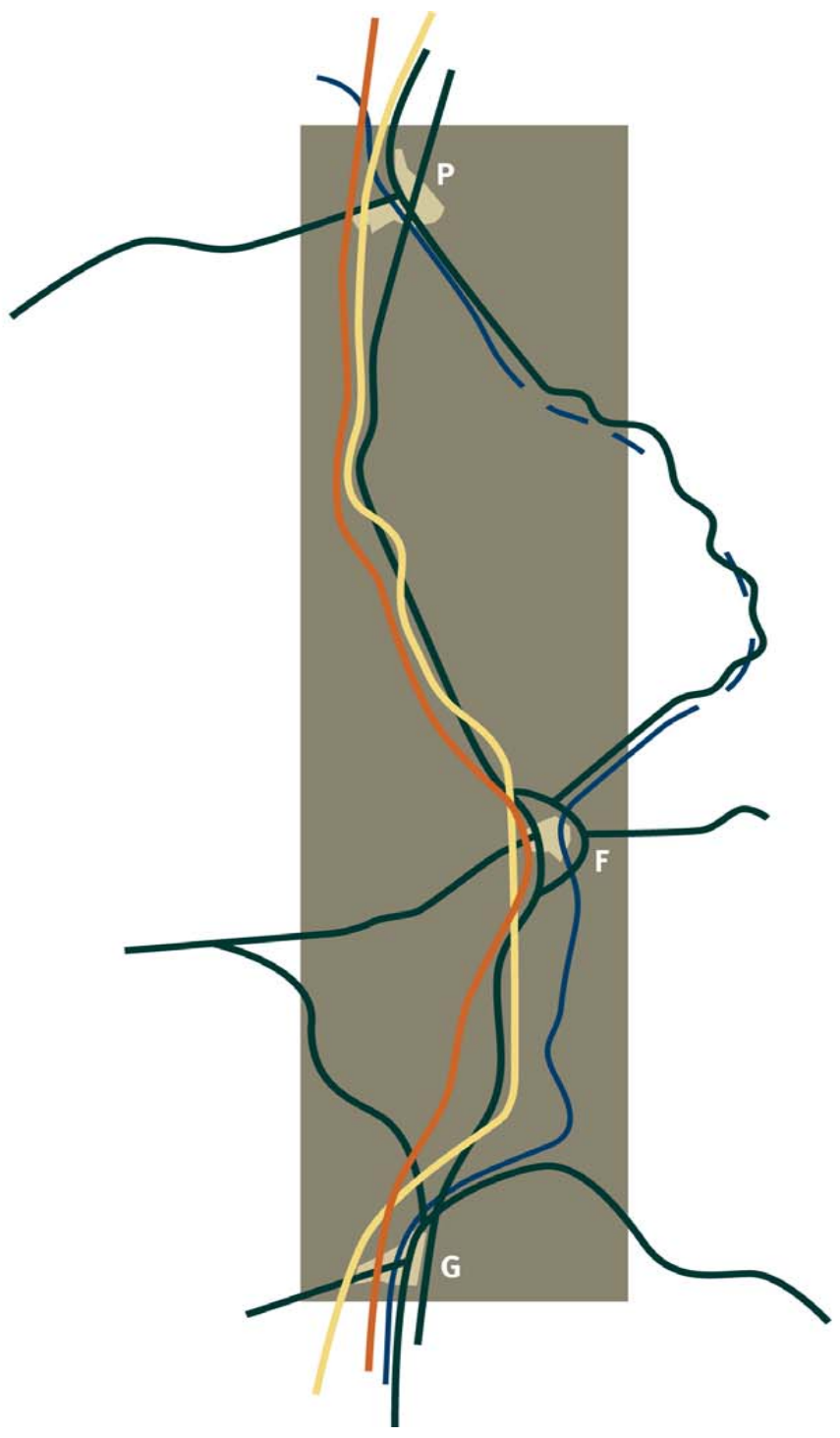













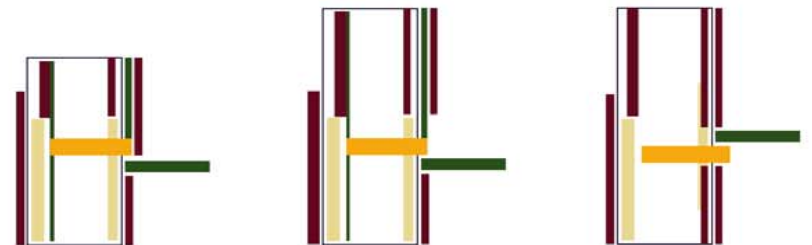
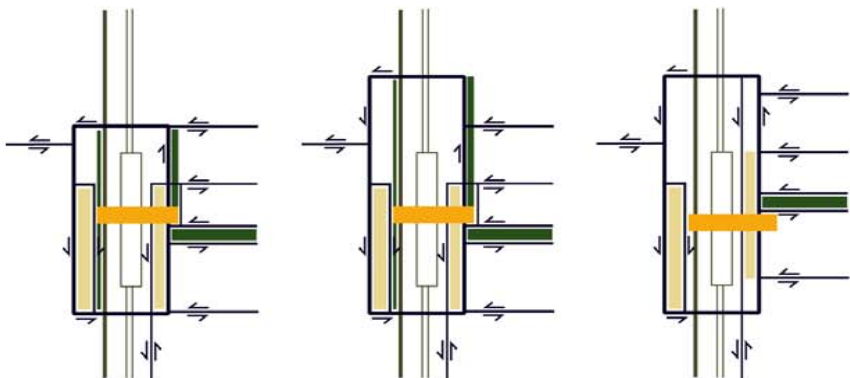
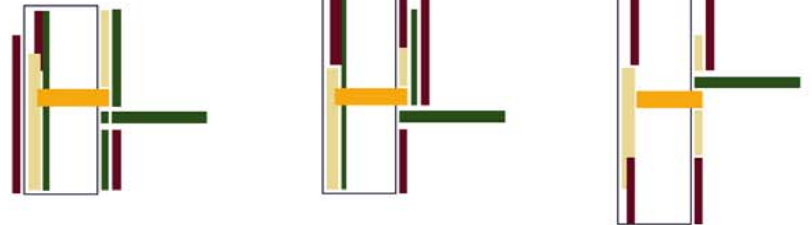
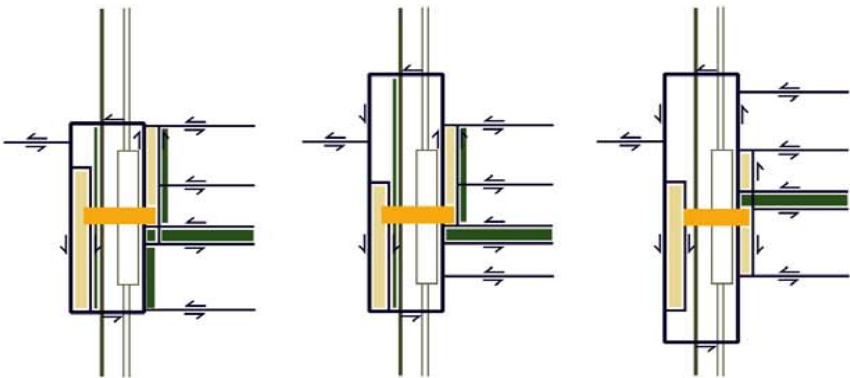
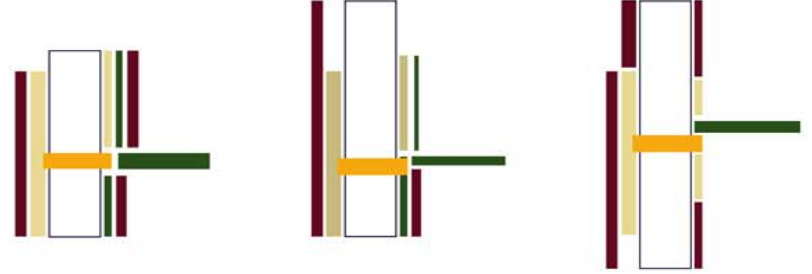
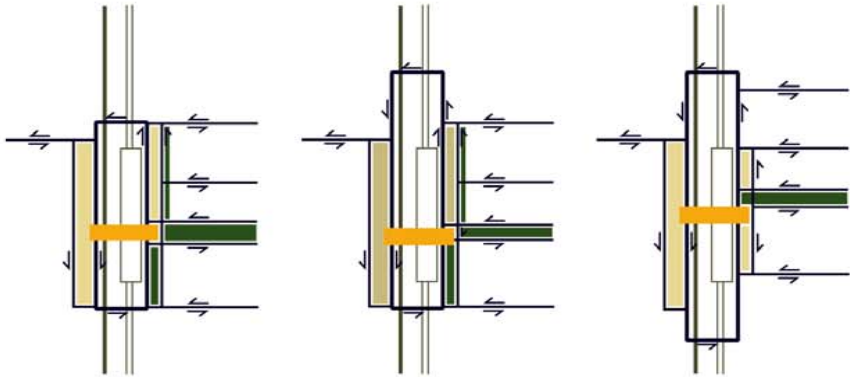





El Plan Especial “Avinguda nova estació”



